

## DATASHEET

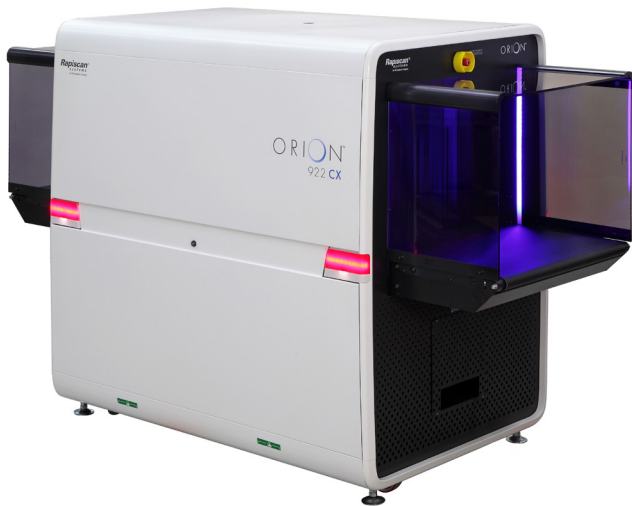

The new 922CX is a High Performance 750mm by 550mm tunnel checkpoint screening system with best in industry resolution and excellent threat detection alert capabilities for large carry-on baggage and parcels at the checkpoint.

INDUSTRY BEST WIRE & SPATIAL RESOLUTION

EXPLOSIVES & NARCOTICS DETECTION

LOW DENSITY IMAGE ENHANCEMENT

MATRIXING, NETWORKING & REMOTE VIEWING



### SPECTRUM 4-COLOR IMAGING

922CX can present images to the operator in the Classic 4-color and the new proprietary Spectrum 4-color (SP4) option providing superior image, allowing improved security by quick and accurate identification of threats and increase in throughput.

### DUAL MODE Z<sub>EFF</sub>

This feature aids the operator in quick identification of organic materials, either in Range Mode which highlights areas based on operator selected Z-effective values of 7, 8 or 9, or in Interactive Mode which gives the operator the option to display the Z-effective number of a selected pixel

### EXPLOSIVES AND NARCOTICS DETECTION

Target and NARCSan are designed to detect a wide range of explosives and narcotics respectively in real time during the scanning process by marking a potential threat on the X-ray image. Rapiscan® Systems detection algorithms are based on regulatory approved material analysis techniques.

### EUROPEAN AVIATION COMPLIANCE

922CX performance is in full compliance with the mandatory regulations (EC) No. 300/2008, (EC) Implementing Regulation 1998/2015 and update 815/2017, EC Implementing Decision 8005/2015 and update 3030/2017 for aviation security in the European Union.

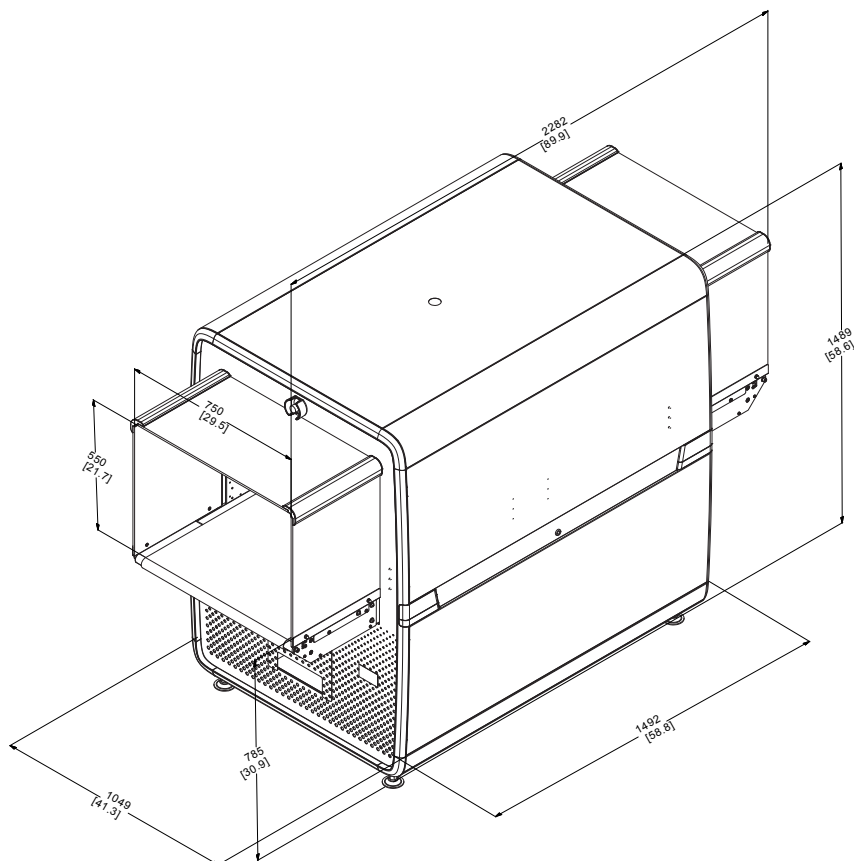

## PHYSICAL SPECIFICATIONS <sup>1</sup>

DIMENSIONS	L	2,282 mm (89.9 in)
	W	1,049 mm (41.3 in)
	H	1,489 mm (58.6 in)
TUNNEL SIZE	W	750 mm (29.4 in)
	H	550 mm (21.5 in)
CONVEYOR HEIGHT		785 mm (30.9 in.)
WEIGHT (NET)		628 Kg (1,385 lbs)

## ENVIRONMENT & POWER

STORAGE TEMPERATURE	-20°C to 50°C
OPERATING TEMPERATURE	0°C to 40°C
RELATIVE HUMIDITY	5 to 95% non-condensing
SYSTEM POWER	100/110/120/200/208 /220/230/240 VAC ±10%

## PERFORMANCE <sup>2</sup>

CONVEYOR SPEED <sup>1</sup>	0.20 m/sec (39.4 ft/min)
CONVEYOR LOAD <sup>1</sup>	165 Kg (364 lbs)
STEEL PENETRATION	38 mm typical, 36 mm standard
WIRE RESOLUTION	42 AWG typical, 40 AWG standard
SPATIAL RESOLUTION	0.8 mm vertical & horizontal

## HIGH SPEED OPTION

CONVEYOR SPEED <sup>1</sup>	0.35 m/sec (68.9 ft/min)
STEEL PENETRATION	31 mm typical, 30 mm standard
WIRE RESOLUTION	38 AWG typical, 36 AWG standard
SPATIAL RESOLUTION	0.8 mm vertical & horizontal

## X-RAY GENERATOR

ANODE VOLTAGE:	160kV
ORIENTATION	Diagonally Upward

## KEY FEATURES AND OPTIONS

Explosive threats, narcotics & density alerts

Spectrum 4

17 Image processing functions

SINERGY low density enhancement

Dual Mode Z-effective

CrystalClear™

Automatic, Enhanced Image Archiving

E.U. Approved Threat Image Projection

Remote Status Monitoring

Remote Archive Review

Multi-System Alarm Resolution Network

Multiplexing and Matrixing

Tray Return System Compatible

13 Languages

64-bit Operating System

# Scan S™

64-bit Operating System

info@rapiscansystems.com

www.rapiscansystems.com



# Rapiscan® systems

An OSI Systems Company

1. Approximate Values 2. Stated performance as measured by Rapiscan® Imaging Validation Test Kit

Rapiscan® Systems is ISO 9001:2015 Certified

Rapiscan® Systems' cabinet X-ray products comply with all applicable U.S. FDA and equivalent international regulatory agency requirements, contained in the cabinet X-ray radiation safety performance standard [21 CFR 1020.40] and the general performance standard [21 CFR Part 1010] as well as IEC standard 61010-2-091. Rapiscan® baggage and parcel inspection systems radiation emission leakages are well below the required regulatory limits with less than 1µSv/hr at 10 cm from all surfaces of cabinet X-ray.

With continual development of our products Rapiscan® Systems reserves the right to amend specifications without notice. Product pictures are for general reference. Please note that due to US laws and regulations, not all Rapiscan® products are available for sale in all countries without restriction. Please contact your Rapiscan® Systems sales representative for more information.

DSBP-0003-922CX-184302