

THREAT DETECTOR FOR CHALLENGING ENVIRONMENTS

Detects CWAs, TICs, explosives, precursors, narcotics and taggants

Designed for challenging environments: extreme temperature, dust, moisture, salt fog, and rain

Physical shock and vibration resistant

Tested to MIL-STD-810-G and IP54 rated

100% Buy American Act compliant



HARDENED MOBILETRACE[®] IS BUILT AROUND A CORE OF FIELD-PROVEN EXPLOSIVES AND NARCOTICS DETECTION TECHNOLOGIES, AND DESIGNED FOR THE CHALLENGING ENVIRONMENTS IN WHICH YOU WORK. IT HAS BEEN TESTED TO MILITARY AND GOVERNMENT STANDARDS AND HAS EXPANDED CAPABILITIES FOR DETECTING CHEMICAL WARFARE AGENTS (CWAs) AND TOXIC INDUSTRIAL CHEMICALS (TICs).

We know your missions are different every time and the environments you encounter are tough and unpredictable. Hardened MobileTrace[®] can help you enhance the safety and success of your mission by screening for explosives, narcotics and other threats, that might otherwise go undetected.

Hardened MobileTrace[®] was designed to make advanced detection technology easy to use in the field. It is a highly portable and lightweight unit equipped with a daylight-readable touch screen for clear and immediate viewing in all lighting conditions. Users who are familiar with other Rapiscan[®] Systems products will recognize the straightforward software and instructions found common in the user interface across many of Rapiscan[®] Systems trace detectors.

DESIGNED FOR CHALLENGING ENVIRONMENTS

Ports and Border.

Military.

Law Enforcement.

RUGGEDIZED

Tested to MIL-STD-810-G.

IP54 Rated.

Temperature range: -20°C to 55°C (-4°F to 131°F).

Humidity range: 0-95% RH non-condensing.

Salt fog resistant.

Drop and vibration tested.

PORTABLE

Lightweight.

Two batteries for up to six hours of operation. Internal backup batteries for "hotswap" ability.

EXPANDED SUBSTANCE DETECTION

Tested and verified at government and third-party labs. CWAs library: blood, blister, nerve.

TICs library: chlorides, cyanides, acids and ammonias.

EASY TO USE

Daylight readable touch screen (800 NIT).

Simple user interface and intuitive menus.

E-mail, and field service engineer technical support and troubleshooting 24/7.

Ergonomically designed for PPE operation.

ACCURATE

Results verified at third-party laboratories.

HARDENED MOBILETRACE®

Rapiscan®
systems
An OSI Systems Company

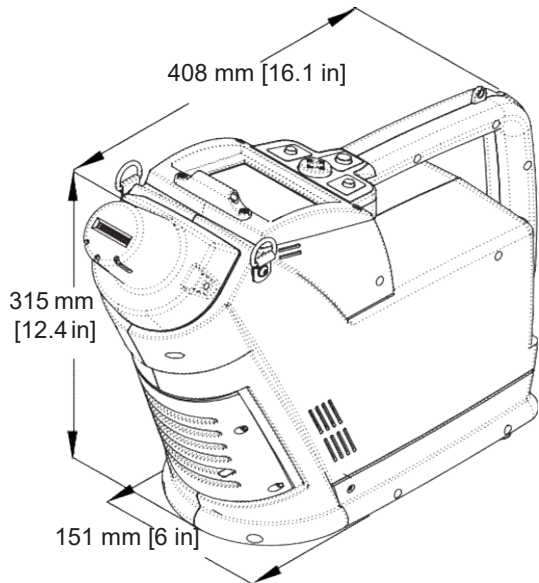

PHYSICAL SPECIFICATIONS

Dimensions: Length: 438 mm (17.3 in.)
Width: 159 mm (6.3 in.)
Height: 324 mm (12.8 in.)
Weight (Approx.): Net: 5.4 Kg (12 lbs) with battery

TECHNICAL SPECIFICATIONS

Detector Type: Ion Trap Mobility Spectrometer (ITMS™); Nickel 63, 10 millicurie (370 MBq) strength
Analysis Time: Less than 12 seconds
Sample Acquisition: Particles wipe or vapors sampling
Sensitivity: Nanogram
False Alarm Rate: Less than 1%
Warmup Time (Cold Start): 24 hours / 30 minutes Operating
Temperature: -20 to 55°C (-4 to 131°F)
Power: 115/230 VAC, 50/60 Hz
Two rechargeable Li-Ion batteries, up to four hours each, charger included Internal back-up batteries to maintain power while swapping batteries
External AC to DC power supply, DC vehicle power adapter, and main battery
Computer: Windows® CE 5.0, 1 GB compact flash disk
Display: 3.5 in. (8.9 cm); color LCD, 800 NIT
Detection Modes: Explosives, narcotics, TICs, CWAs
Data Transfer Capability: Ethernet and USB connectivity
Environmental: IP54, MIL-STD-810-G: resistant to blowing dust, rain, salt fog, vibration, physical shock

With continual development of our products Rapiscan® Systems reserves the right to amend specifications without notice. Product pictures are for general reference. Please note that due to US laws and regulations, not all Rapiscan® products are available for sale in all countries without restriction. Please contact your Rapiscan® Systems sales representative for more information.



Rapiscan® Systems is ISO 9001:2008 Certified

AMERICAS, CARIBBEAN
2805 Columbia Street
Torrance,
California
90503
UNITED STATES of AMERICA
Tel: +1 310-978-1457
Fax: +1 310-349-2491

EUROPE, MIDDLE EAST, AFRICA
X-Ray House
Bonehurst Road
Salfords
Surrey RH1 5GG
UNITED KINGDOM
Tel: +44 (0) 870-7774301
Fax: +44 (0) 870-7774302

ASIA
240 Macpherson Road
#07-01 Pines Industrial Building
Singapore
348574
SINGAPORE
Tel: +65-6846-3511
Fax: +65-6743-9915

sales@rapiscansystems.com
www.rapiscansystems.com