

RAPISCAN 620DV



Checkpoint Screening System approved as an Advanced Technology (AT) system by U.S. TSA, Liquid Explosive Detection System (LEDS) by E.U and certified by CAAC.

High Performance Advanced Checkpoint Screening

Dual View Technology

Automatic Detection of Solid and Liquid Explosives and Narcotics

Largest Global Regulatory Approvals



Shown with optional Operator Pedestal

The Rapiscan 620DV is an advanced checkpoint screening solution, designed for aviation and high security applications. It uses innovative dual view technology to generate a horizontal and vertical view of the object under inspection.

Rapiscan 620DV has been approved and included on the qualified list applicable to the U.S. TSA Advanced Technology (AT) checkpoint program as well as the qualified list applicable to E.U. ECAC Liquid Explosive Detection System (LEDS) Common Evaluation Process (CEP) for security equipment.

Rapiscan 620DV provides unsurpassed image quality, regulatory approved automatic detection of solid explosive software (Target™) and Automatic Liquid Explosive Identification Software (aLEXis™) with the largest global approvals and certifications.

Tunnel Opening (width x height):
640 x 430 mm (25.2 x 16.9 in)

Standard Features

- Multi Energy Imaging (4 Color)
- View Previous/Next Bag
- Manual Image Archive
- Configurable Image Processing Keys
- Baggage Counter
- Date / Time Display
- Search Indicator
- UPS (Uninterrupted Power Supply)
- Flat Panel Monitor

Standard Image Processing Functions

- Crystal Clear™
- Black and White
- Organic / Inorganic Stripping
- Inverse Video
- High Penetration
- Pseudo Color
- Low Penetration
- Variable Edge Enhancement
- Variable Color Stripping
- Variable Gamma
- Variable Density
- Dynamic Continuous Zoom & Panning
- Fixed Zoom (64x)

Automatic Detection of Explosives

Target™ automatically detects a wide range of solid and liquid explosives in real time during the scanning process by visibly highlighting a potential threat on the X-ray image.

Automatic Detection of Narcotics

NARCScan™ automatically detects a wide range of narcotics in real time during the scanning process by visibly highlighting a potential threat on the X-ray image.

Meeting Today's Most Stringent Global Requirements

The Rapiscan 620DV meets the most rigorous detection and image quality requirements as set by the U.S. Transportation Security Administration (TSA), U.K. Department of Transport (DfT), European Union, French civil aviation authority (STAC), Civil Aviation Administration of China (CAAC), and Transport Canada (TC).

Greatest Number of Operator-Assist Tools Enables Highest Throughput

With over 13 image processing tools and multiple automatic detection functions, the feature rich software helps the operator easily and accurately detect contraband for the highest throughput and least operator fatigue.

Regulatory Compliance

Rapiscan 620DV image quality performance is in compliance with regulation (EC) No. 300/2008. In addition, Rapiscan 620DV Threat Image Projection (TIP) is in compliance with regulation (EU) No. 185/2010.

Dual View Advanced Technology

Government regulators such as U.S. Transportation Security Administration (TSA) require dual view technology for screening objects. The 620DV is able to produce two (2) separate simultaneous images from perpendicular orientations providing a more complete image, reducing the need for repositioning and rescanning and enabling rapid, accurate and comprehensive threat detection.



Rapiscan[®]
systems

An OSI Systems Company

RAPISCAN 620DV

Physical Specifications

Dimensions:	Length: 2,880 mm (113.4 in.) Width: 1,430 mm (56.3 in.) Height: 1,418 mm (55.8 in.)
Tunnel Size:	640 mm (W) x 430 mm (H) (25.2 x 16.9 in.)
Conveyor Speed:	0.22 m/sec (43.3 ft./min)
Conveyor Load:	165 Kg (364 lbs) evenly distributed
Conveyor Height:	826 mm (32.5 in.)
Approx Weight:	Net: 1000 Kg (2,205 lbs)
System Power:	115/230 VAC ±10%, 60/50Hz

X-Ray Generator and Image Performance*

Steel Penetration:	35 mm guaranteed, 40 mm typical
Wire Resolution:	38 AWG guaranteed, 40 AWG typical
Material Separation:	Low Z, Medium Z, High Z to 0.5 Z accuracy
Generator Cooling:	Sealed oil bath with forced air
Anode Voltage:	Operating at 160kV
Tube Current:	1.0 mA
Orientation:	Vertical and Horizontal

Operating Environment

Storage Temperature:	-20°C to 50°C
Operating Temperature:	0°C to 40°C
Relative Humidity:	5 to 95% non-condensing

Health & Safety

Rapiscan Systems' cabinet X-ray products comply with all applicable US FDA and equivalent international regulatory agency requirements, contained in the cabinet X-ray radiation safety performance standard [21 CFR 1020.40] and the general performance standard [21 CFR Part 1010]. Rapiscan Systems certifies each cabinet X-ray product has a maximum radiation emission leakage of less 1 µSv/hr (0.1 mR/hr) from all external surfaces of the cabinet X-ray system.

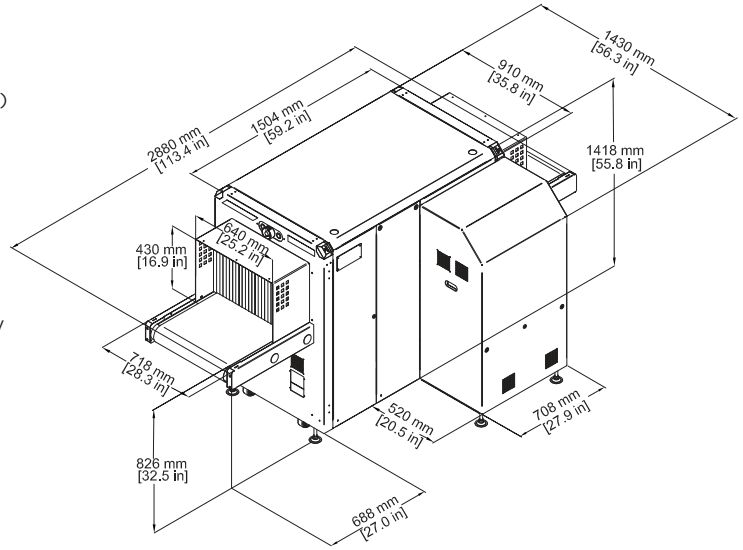

Options and Accessories

**aLEXis™ (Automatic detection of Liquids, Aerosols and Gels (LAGs) explosives)	Automatic Image Archiving
Target™ / Interactive Target™ (Automatic detection of solid explosives)	Enhanced Image Archiving
NARCSan™ (Automatic detection of narcotics)	Computer Based Operator Training (CBT)
Density Threshold Alert (DTA)	Operator Training Program (OTP)
Threat Image Projection (TIP)	Manual Scan
Threat Image Projection Network (TIPNet)	Operator Pedestal
NETView™ (Remote network image archive review)	Foot-mat
NEXLink™ (Advanced network X-ray management automation and link system)	Optical Operator Presence Sensor
Multi-System Alarm Resolution Network Display Station (NDS)	SmartCard Login
	Power Conditioner
	Conveyor Accessories
	Remote Workstation
	Universal Printer Support

*Stated performance as measured by Rapiscan Imaging Validation Test Kit. Stated Dual View performance as measured in primary view.

**Please request from your local sales representative for the kit specific part numbers when ordering aLEXis™.

With continual development of our products Rapiscan Systems reserves the right to amend specifications without notice. Product pictures are for general reference. Please note that due to US laws and regulations, not all Rapiscan products are available for sale in all countries without restriction. Please contact your Rapiscan Systems sales representative for more information.

AMERICAS, CARIBBEAN
2805 Columbia Street
Torrance, California 90503
UNITED STATES OF AMERICA
Tel: +1 310-978-1457
Fax: +1 310-349-2491

EUROPE, MIDDLE EAST, AFRICA
X-Ray House
Bonehurst Road
Salfords
Surrey RH1 5GG
UNITED KINGDOM
Tel: +44 (0) 870-7774301
Fax: +44 (0) 870-7774302

ASIA
240 Macpherson Road
#07-01 Pines Industrial Building
Singapore 348574
SINGAPORE
Tel: +65-6846-3511
Fax: +65-6743-9915

EMAIL
sales@rapiscansystems.com

WEB
www.rapiscansystems.com

Rapiscan
systems
An OSI Systems Company



Rapiscan Systems is
ISO 9001:2008 Certified

ONE COMPANY - TOTAL SECURITY

www.rapiscansystems.com